



# MODEL CS900

## GRAVITY FROZEN BEVERAGE FREEZER

### FEATURES

**This high-volume slush freezer delivers exceptional frozen beverages in a compact footprint.**

#### High Capacity Hopper

Ensures fast, consistent dispensing of frozen beverages, maximizing output and minimizing downtime in high-volume operations.

#### Patented Torque Control Technology

Maintains consistency & product texture.

#### Easy to Operate and Clean

Designed for reliability, minimizing downtime and maintenance.

#### Washable Air Filter

Keeps the condenser clean for optimal performance.

#### Compact, Space-Saving Design

A perfect fit for any foodservice operation. Available as a countertop model or with an optional cart.

#### Innovative Auger Technology

Gently blends to preserve texture, consistency, and quality.

#### Long Lasting Scraper Blades

Durable reversible scraper blades minimizes replacements while ensuring a smooth, consistent texture for premium-quality frozen treats.



#### Optional Cart



### PERFECT FOR

- High-Traffic Venues
- Quick Service Restaurants
- Resorts
- Bars



CS900



# MODEL CS900 SPECIFICATIONS

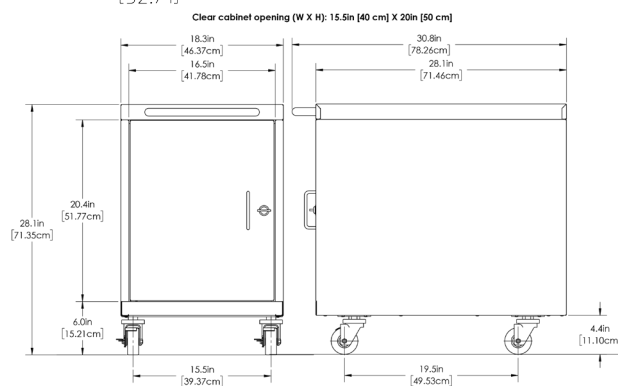
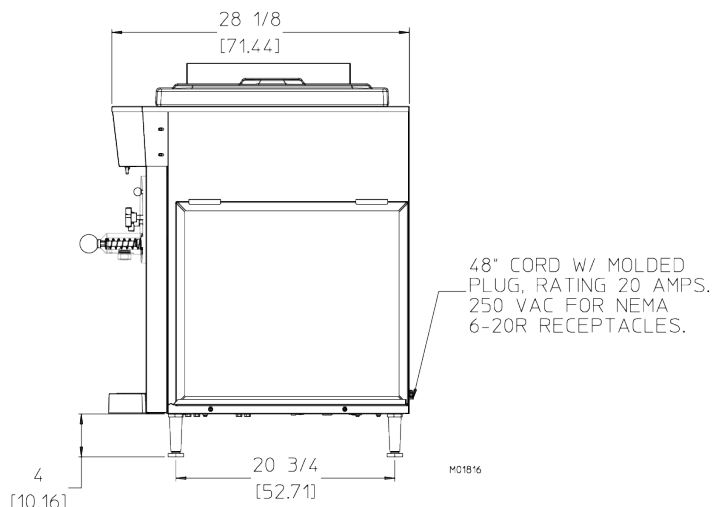
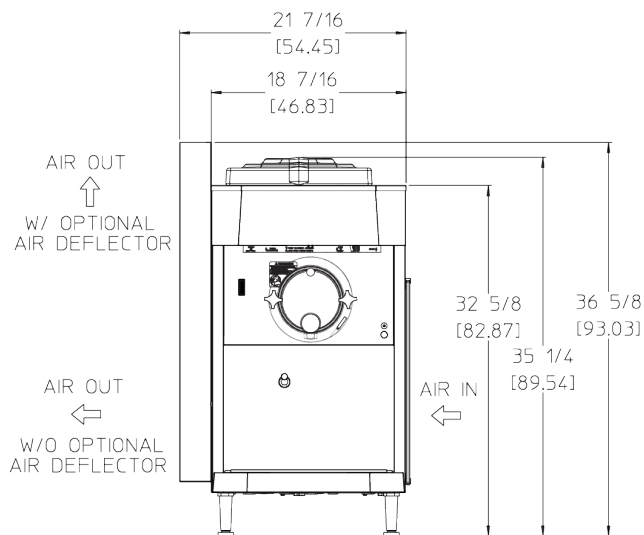

## Weight

Net	260 lbs	117.9 kg
Crated	356 lbs	161.5 kg

## Volume

39.47 cubic ft 1.12 cubic m

## Dimensions

18-7/16" x 28-1/8" x 35-1/4"  
46.83 cm x 71.44 cm x 89.54 cm

## Mix Hopper Capacity

One - 20 qts (18.8 liters) each

## Freezing Cylinder Capacity

One - 7.6 qts (7.2 liters) each

## Beater Motor- Qty, hp

One, 1/4 hp

## Refrigerant Types\*

One, 10,000 Btuh  
R404a R452a

\*Customer is responsible for complying with local refrigeration regulations.

## Electrical

	Total Amps (qty)	NEMA Plug Type	Poles (P) Wires(W)
208-230/60/1 Air	12.5 A	6-20 P	2P 2W

## Exterior Space Required

Air Cooled: 3" (7.6 cm) air space required on both sides & rear panel for circulation

## Optional Features

Refrigerated Hopper: for perishable bases (order "N" model)

Top Air Discharge Chute: allows air flow to divert upward

Cabinet: commercial grade stainless steel with heavy duty casters, a sturdy latch and 6 cubic feet of storage

Flavor Rack

Certified and/or listed by:



\*UL listed and listed by Underwriters Laboratories under Canadian National Standard C22.2 No. 120-13



DISTRIBUTOR



LOCATOR