



# MODEL CS700 GRAVITY SHAKE FREEZER

## FEATURES

**This countertop shake freezer comes in a compact footprint while delivering outstanding product quality; making it perfect for high-demand environments.**

### Easy to Operate and Clean

Designed for reliability to minimize downtime.

### Innovative Auger Technology

Gently blends to preserve texture, consistency, and quality.

### Washable Air Filter

Keeps the condenser clean for optimal performance.

### Compact, Space-Saving Design

A perfect fit for any foodservice operation.

### Precision Consistency Control

Designed to consistently dispense quality product.

### Long Lasting Scraper Blades

Durable reversible scraper blades minimizes replacements while ensuring a smooth, consistent texture for premium-quality frozen treats.



### Optional Cart



## PERFECT FOR

- Amusement Park Kiosks
- Frozen Treat Shops
- High-Volume Restaurants
- Quick Service Restaurants



CS700



# MODEL CS700 SPECIFICATIONS

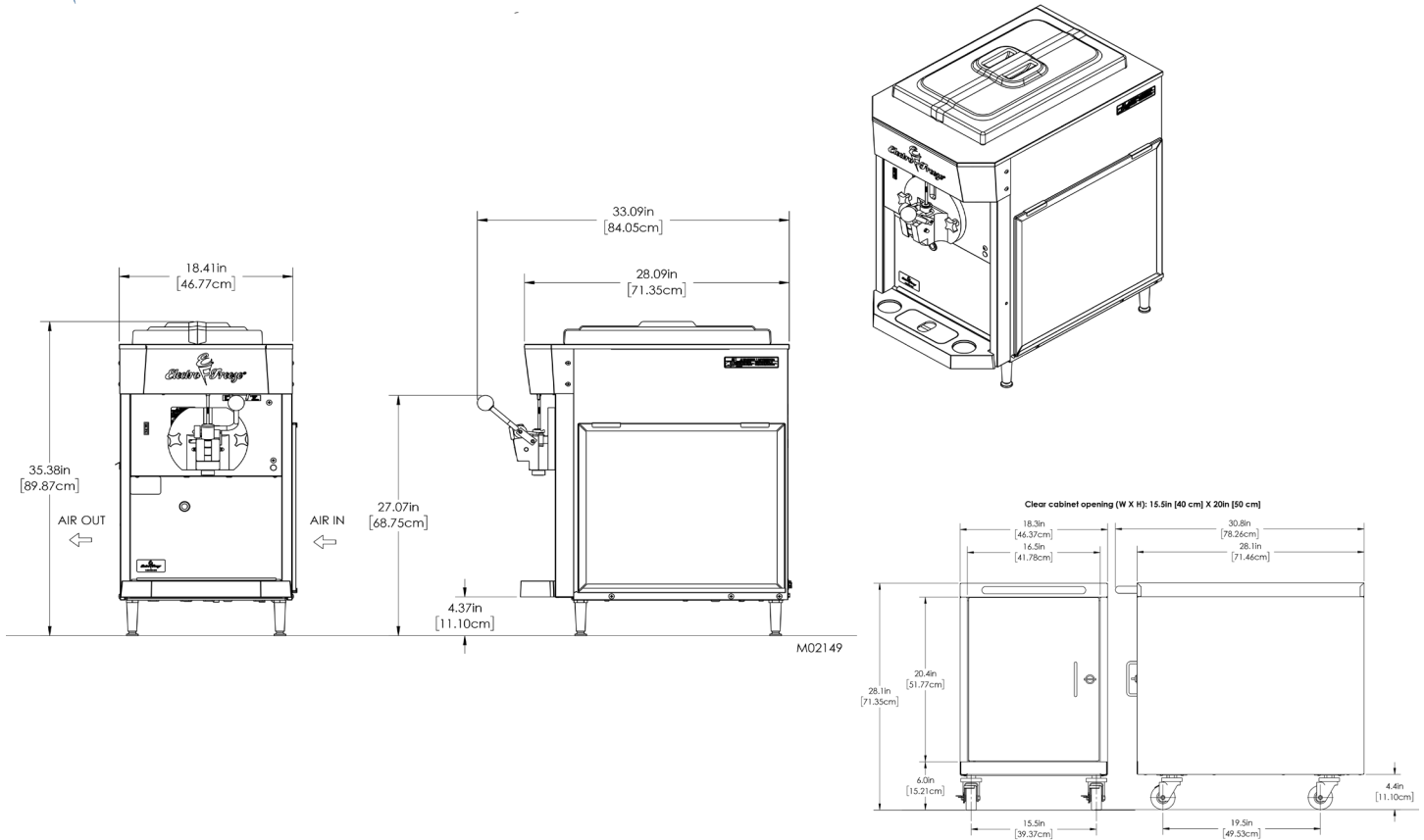

## Weight

Net	260 lbs	117.9 kg
Crated	356 lbs	161.5 kg

## Volume

39.47 cubic ft 1.12 cubic m

## Dimensions

18.41" x 33.09" x 35.38"  
46.77cm x 84.05cm x 89.87cm

## Mix Hopper Capacity

One - 20 qts (18.8 liters) each

## Freezing Cylinder Capacity

One - 7.6 qts (7.1 liters) each

## Beater Motor- Qty, hp

One, 1/2 hp

## Refrigerant Types\*

One, 8,000 Btuh  
R404a R452a

\*Customer is responsible for complying with local refrigeration regulations.

## Electrical

	Max Fuse Size	NEMA Plug Type	
208-230/60/1 Air	20	6-20 P	
209-230/60/1 Water	20	6-20 P	
	Total Amps (qty)	kW	Poles (P) Wires(W)
220-240/50/1 Air	12	1.78	2P 2W

## Exterior Space Required

**Air Cooled:** 3" (7.6 cm) air space required on both sides & rear panel for circulation

## Optional Features

**Top Air Discharge Chute:** allows air flow to divert upward

**Cabinet:** commercial grade stainless steel with heavy duty casters, a sturdy latch and 6 cubic feet of storage

**Multiple Types of Blades:** provides desired consistencies from smooth creamy shakes to thick hand spun shakes.

## Front Mount Shake Mixer

Certified and/or listed by:



\*UL listed and listed by Underwriters Laboratories under Candian National Standard C22.2 No. 120-13

\*\*Selected voltages only. Contact Electro Freeze® / H.C. Duke to verify agency needs



## DISTRIBUTOR



LOCATOR